

## GENERAL INFO

## SPARES &amp; FITTINGS

Quality water filtration products need quality fittings.

Puretec fittings are a fast and easy way to distribute a wide range of liquids and gases. The Puretec fittings have a unique oval-shaped collet, making it easier to grip, easier to connect and easier to disconnect. The rounded stainless teeth within the fittings are the secret to a perfect seal and a proprietary design minimises the wear on the tube, this allows for more frequent reuse of the tube and fittings.

## PRODUCT LISTING



New SmartTee™  
for quick and easy  
installation.

**Kwik Connect™ | SmartTee™ Connector**

Ordering Code	Type	Size
<b>KASV47</b>	Angle stop tee valve	¼" Tube x ½" M x ½" F <b>POPULAR</b>

**Kwik Connect™ | Elbow Connector**

Ordering Code	Type	Size
<b>KEC44</b>	Tube to tube	¼" Tube <b>POPULAR</b>
<b>KEC55</b>	Tube to tube	5/16" Tube
<b>KEC66</b>	Tube to tube	¾" Tube
<b>KEC77</b>	Tube to tube	½" Tube

**Kwik Connect™ | Elbow Adaptor**

Ordering Code	Type	Size
<b>KEA42</b>	Tube to male thread	¼" Tube x ½" M
<b>KEA44</b>	Tube to male thread	¼" Tube x ¼" M <b>POPULAR</b>
<b>KEA64</b>	Tube to male thread	¾" Tube x ¼" M
<b>KEA66</b>	Tube to male thread	¾" Tube x ¾" M

**Kwik Connect™ | Reducer**

Ordering Code	Type	Size
<b>KRR64</b>	Stem to tube	¾" Stem x ¼" tube

**Kwik Connect™ | Straight Adaptor**

Ordering Code	Type	Size
<b>KSA44</b>	Tube to male thread	¼" Tube x ¼" M
<b>KSA46</b>	Tube to male thread	¼" Tube x ¾" M
<b>KSA47</b>	Tube to male thread	¼" Tube x ½" M
<b>KSA66</b>	Tube to male thread	¾" Tube x ¾" M
<b>KSA64</b>	Tube to male thread	¾" Tube x ¼" M
<b>KSA77</b>	Tube to male thread	½" Tube x ½" M

**Kwik Connect™ | Reducing Straight Connector**

Ordering Code	Type	Size
<b>KRS64</b>	Tube to tube	¾" Tube x ¼" tube <b>POPULAR</b>
<b>KRS76</b>	Tube to tube	½" Tube x ¾" tube



Kwik Connect™ | Tap Adaptor

Ordering Code	Type	Size
<b>KTA44</b>	Tap adaptor	¼" Tube x ¼" F
<b>KTA47</b>	Tap adaptor	¼" Tube x ½" F
<b>KTA48</b>	Tap adaptor (faucet adaptor)	¼" Tube x 7/16" F
<b>KTA49</b>	Tap adaptor	¼" Tube x ¾" F
<b>KTA66</b>	Tap adaptor	¾" Tube x ¾" F
<b>KTA67</b>	Tap adaptor	¾" Tube x ½" F
<b>KTA77</b>	Tap adaptor	½" Tube x ½" F



Kwik Connect™ | Tee Adaptor

Ordering Code	Type	Size
<b>KTC44</b>	Tube to tube	¼" Tube
<b>KTC66</b>	Tube to tube	¾" Tube
<b>KTC77</b>	Tube to tube	½" Tube



Kwik Connect™ | Straight Connector

Ordering Code	Type	Size
<b>KSC44</b>	Tube to tube	¼" Tube <b>POPULAR</b>
<b>KSC66</b>	Tube to tube	¾" Tube
<b>KSC77</b>	Tube to tube	½" Tube



Kwik Connect™ | Stem Adaptor

Ordering Code	Type	Size
<b>KSM67</b>	Stem to male thread	¾" Stem x ½" M



Kwik Connect™ | Shutoff Valve

Ordering Code	Type	Size
<b>KSOV44</b>	Shutoff valve	Straight ¼" tube x ¼" tube
<b>KSOV44N</b>	Shutoff valve	Straight ¼" tube x ¼" M
<b>KSOV66</b>	Shutoff valve	Straight ¾" tube x ¾" tube
<b>KSOV77</b>	Shutoff valve	Straight ½" tube x ½" tube

Accredited by



**HOW TO CONNECT**

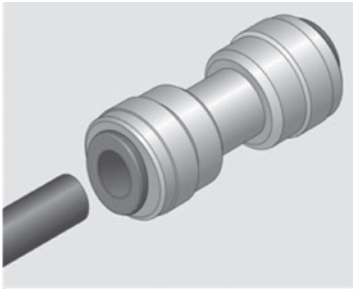

**Step 1.**  
Cut the part of the tube to be inserted into the fitting to plane the end.  
Make sure to use a clean tube without any foreign material or cracks.

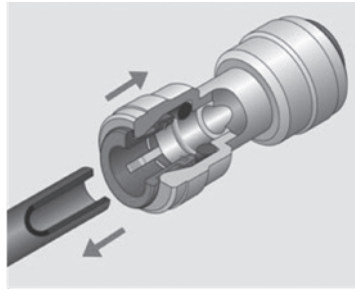

**Step 2.**  
When inserting the tube, remove any obstructions before fully inserting the tube. Make sure the tube is fully inserted.  
Inserting the tube into the fitting only takes moderate force. The tube or fitting should not be scratched or damaged in the process, as this is the main cause for water leaks later on.

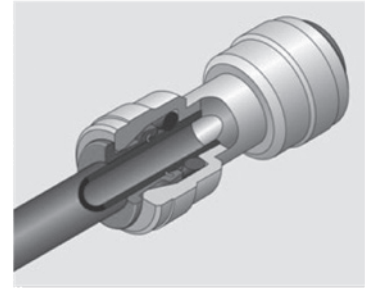

**Step 3.**  
To make sure that the fitting is properly connected to the tube, pull it once. After pulling, insert a spanner under the collet and push the tube into the fitting once more for a complete insertion.

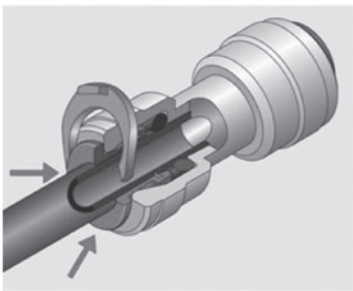

**Step 4.**  
In sensitive applications use our KLC Locking clips to eliminate any inadvertent tampering with the collet and potential release of the fitting.

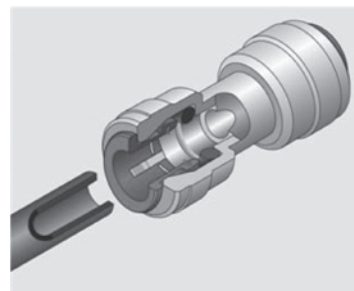

**Step 5.**  
Make sure to completely eliminate pressure before disassembling the fitting.  
When disassembling the tube, push the clip in the direction of the main assembly and then pull the tube out for easy disconnection. Fittings and tubes can be reused.

**FITTINGS CONFIGURATIONS & MATERIALS**

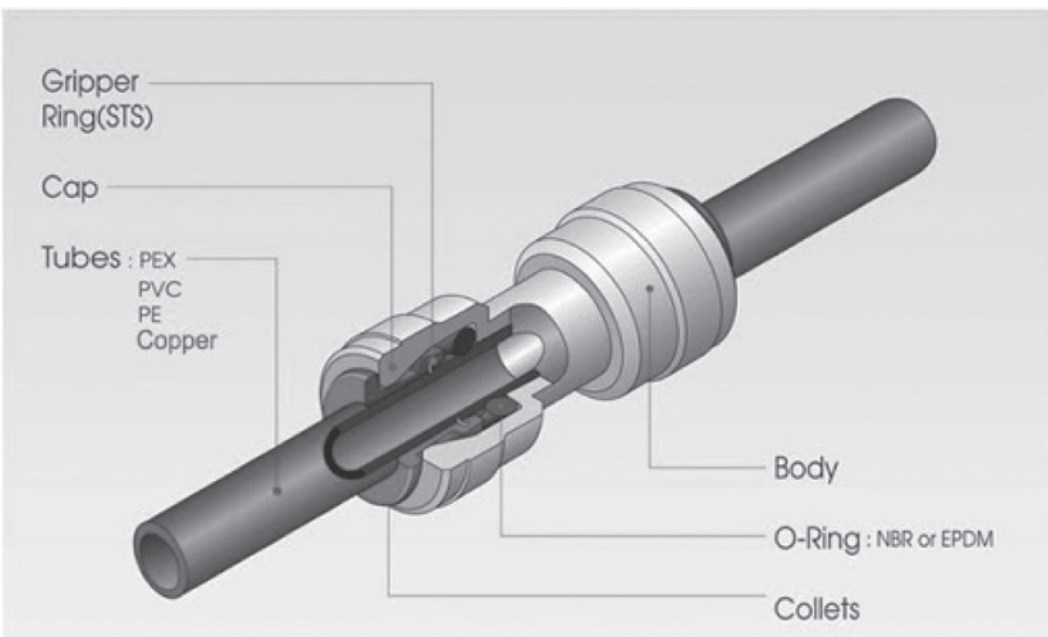

## SPECIFICATIONS

### Fittings Working Pressure & Temperature

	Size	Small Size						Large Size				
		5/32"	3/16"	1/4"	5/16"	3/8"	1/2"	5/8"		7/8"		28mm
		4mm	5mm	6mm	8mm	10mm	12mm	15mm	16mm	18mm	22mm	
Temp.	1°C	1600 kPa (230 psi)			1100 kPa (170 psi)			1100 kPa (170 psi)				
	20°C	1600 kPa (230 psi)			1100 kPa (170 psi)			1100 kPa (170 psi)				
	65°C	1000 kPa (150 psi)			700 kPa (100 psi)			700 kPa (100 psi)				

### Maximum Permissible Torque

	Thread	1/8", 1/4"		3/8", 1/2"		3/4"
Maximum Torque (Nm)	Plastic	1.5		3		4
	Steel	7.0~9.0	12.0~14.0	22.0~24.0	28.0~30.0	40

### Material & Structure

Material	Fitting Colour	O-ring
Acetal / Polyoxymethylene (POM)	White, Grey, Black	NBR, EPDM
Polypropylene	White	EPDM

## WARNINGS & PRECAUTIONS

- Fittings are not recommended for use with liquids other than water and food or beverage products. Where fittings may be used with other chemicals contact Puretec for advice.
- Do not disassemble or modify the individual product, as this may cause a product malfunction, leak, or failure and voids the product warranty.
- Do not over-stress the fitting by rotation, twist, bending, shock, fatigue, or other excess force. This may damage the fitting and cause malfunction, leak, or failure and voids the product warranty.
- Do not use the product where ambient temperature or fluid temperature exceeds 65°C. This may damage the fitting and cause malfunction, leak, or failure and voids the product warranty.
- Do not use liquid adhesives/liquid thread sealers. Only use Teflon tape to seal threaded connections.
- If your plumbed line is used as an electrical ground, you must use a jumper wire to provide continuity across plastic fittings and tubing.
- Never press the collet toward the body unless attempting to separate tubing from a fitting in an unpressurised line. The use of the Puretec Locking Clip is advised to restrict inadvertent disassembly of connections.
- Puretec reserves the right to modify the product from time-to-time as required for quality improvement and as per market requirements. Actual products may differ from pictures shown.
- Connecting Puretec fittings to tubing or connecting elements other than Puretec products is not warranted for performance. Always perform any checks and testing necessary to verify acceptable function.
- Before making any tube connection, verify that the end of the tube has been cut squarely and there are no scratches on the tube O.D within 30mm of the end.
- When making a tube connection, occasionally a gripping of the tube may occur just as the tube begins to pass through the o-ring, although the seal is not yet made. In this case, continue to push the tube deeper into the fitting to complete a secure connection. Failure to completely seat the tube into the fitting may cause a leak.
- When using metallic tubing, deburr the tube ends to avoid potential cutting or other damage to the o-ring.
- After assembling a tube connection, tug with moderate force to check the fitting is holding the tube securely.
- Before disassembling tube connections, always verify that pressure has been removed from the system.
- When disassembling tube connections, always press the collet evenly toward the body and then pull the tube. If a locking clip is used, remove the locking clip before attempting to separate a tube connection.
- When tightening threaded fittings, use care not to over-torque the fitting as this may damage the fitting and cause a leak or other failure.
- Use tube inserts with soft tube and/or tube used in applications with high water temperature up to 65°C.

## CHEMICAL RESISTANCE OF MATERIALS

Puretec fittings have a very good resistance to inorganic chemicals, oils and fats and synthetic detergents this allows these products to be used in a broad range of applications. Please call Puretec if you have any questions about your application.

✓ = Compatible x = Non-Compatible

Chemical (%)	Temp (°C)	Brass	SUS	Resin		Rubber	
				Acetal	PP	NBR	EPDM
Acetic Acid (10%)	20	x	✓	x	✓	✓	✓
Acetic Acid (100%)	20	x	x	x	x	-	-
Acetic Acid (50%)	20	x	✓	x	✓	-	-
Acetic Acid (50%)	70	x	✓	x	x	-	-
Acetone	20	✓	x	✓	x	x	✓
Air	20	✓	✓	✓	✓	✓	✓
Aluminium Sulfate	20	x	x	✓	✓	✓	✓
Animal Oil (Lard Oil)	20	✓	-	✓	✓	✓	✓
Ammonia	20	x	✓	✓	✓	✓	✓
Ammonium Chloride	20	x	x	✓	✓	✓	✓
Ammonium Nitric	20	x	✓	✓	✓	✓	✓
Ammonium Phosphate	20	x	x	✓	✓	✓	✓
Benzene (Benzol)	20	x	x	✓	x	x	x
Boric Acid	20	✓	✓	✓	✓	✓	✓
Bunker Oil	20	x	-	-	✓	✓	-
Butane	20	✓	✓	✓	✓	✓	x
Calcium Chloride	20	✓	x	✓	✓	✓	✓
Calcium Hydroxide	20	x	x	✓	✓	✓	✓
Carbon Tetrachloride	20	x	x	✓	x	x	x
Castor Oil	20	✓	✓	✓	✓	✓	✓
Caustic Soda (10%)	20	x	x	✓	✓	✓	✓
Chromic Acid (10%)	70	x	x	x	x	-	-
Chromic Acid (2%)	70	x	x	x	x	-	-
Chromic Acid (2%)	50	x	x	x	x	x	✓
Chromic Acid (25%)	70	x	x	x	x	-	-
Cresol	20	✓	x	x	✓	x	x
Ethyl Alcohol (Ethanol)	20	✓	✓	✓	✓	✓	✓
Fluorine	20	x	x	x	x	-	x
Formic Acid (25%)	20	x	x	x	✓	✓	✓
Gasoline	20	✓	✓	✓	x	✓	x
Glucose	20	✓	✓	✓	✓	✓	✓
Glycerin	20	✓	✓	✓	✓	✓	✓
Grease	20	✓	✓	✓	x	✓	x
Hydrochloric Acid (10%)	20	x	x	x	✓	-	-
Hydrochloric Acid (20%)	20	x	x	x	✓	-	-
Hydrochloric Acid (20%)	80	x	x	x	x	x	x
Hydrochloric Acid (38%)	20	x	x	x	✓	✓	✓

Chemical (%)	Temp (°C)	Brass	SUS	Resin		Rubber	
				Acetal	PP	NBR	EPDM
Hydrogen	20	x	✓	✓	✓	✓	✓
Hydrogen Sulfide	20	x	x	✓	✓	x	✓
Kalium Chloride	20	x	x	✓	✓	✓	✓
Kerosene	20	✓	✓	✓	✓	✓	x
Ketones	20	✓	✓	✓	✓	-	✓
Liquefied Petroleum Gas (LPG)	20	✓	✓	✓	✓	✓	x
Lye Solution	20	-	-	✓	✓	✓	✓
Mercury	20	x	-	-	✓	✓	✓
Methane	20	✓	✓	✓	✓	✓	x
Methyl Alcohol (Methanol)	20	✓	x	✓	✓	✓	✓
Mineral Oil	20	✓	✓	✓	✓	✓	x
Naphtha	20	x	✓	✓	x	x	x
Natural Gas	20	✓	✓	✓	✓	✓	x
Nitrogen	20	✓	✓	✓	✓	✓	✓
Olive Oil	20	x	✓	✓	✓	✓	✓
Oxygen	20	✓	✓	✓	✓	✓	✓
Ozone	20	✓	✓	x	x	✓	✓
Petroleum	20	x	x	✓	x	✓	x
Potassium Sulfate	20	✓	x	✓	✓	✓	✓
Propane	20	✓	✓	✓	✓	✓	x
Salt Water	20	x	x	x	✓	-	-
Sea Water	20	x	✓	✓	✓	-	-
Silicone Greases	20	-	-	✓	x	✓	✓
Silicone Oil	20	-	-	✓	x	✓	✓
Soda Ash (Sodium Carbonate)	20	✓	x	✓	✓	✓	✓
Sodium Cyanide	20	x	-	-	-	✓	✓
Sodium Phosphate	20	x	x	✓	✓	✓	✓
Sodium Silicate	20	✓	-	✓	✓	✓	✓
Chemical (%)	Temp (°C)	Brass	SUS	Resin		Rubber	
				Acetal	PP	NBR	EPDM
Soybean Oil	20	x	✓	✓	✓	✓	x
Steam	150	✓	-	x	x	x	✓
Sulfur	20	x	✓	✓	✓	x	✓
Sulfuric Acid (10%)	20	x	x	x	✓	x	✓
Sulfuric Acid (10%)	70	x	x	x	x	-	-
Sulfuric Acid (30%)	20	x	x	x	✓	-	-
Sulfuric Acid (30%)	70	x	x	x	x	-	-
Sulfuric Acid (98%)	20	x	x	x	x	-	-
Sulfurous Acid Gas	20	-	-	x	✓	✓	✓
Toluene	20	✓	✓	✓	x	x	x
Vegetable Oil	20	-	-	✓	✓	✓	✓
Water	20	✓	✓	✓	✓	✓	✓
Water	100	x	✓	x	x	-	-